



CHUCK

デュアルロックチャック

DL200 series

2段階把握

多彩な把握で思い通りの加工を



●多彩な把握で高い生産性を実現!

KITAGAWAが開発した2段階把握。ジョーが平行移動してワークを把握、そして引込んで着座します。従来のジョー引込みチャックのようにジョーがZ方向に飛び出さないためワークとの干渉がなく、狭い部分や入り組んだ部分の把握が可能です。また、把握径はチャック外径まで広く、内径把握仕様でも使用できます。把握場所を選ばない多彩な把握で、様々なワークに対応します。前後工程に合わせた柔軟な加工に対応し、生産性の向上に貢献します。

●量産加工に最適!

防塵、グリス密封構造で、耐久性に優れたチャックです。量産加工、自動化ライン導入に最適です。

●ジョー成形が簡単!

ジョーには、セレーションジョーを採用。お客様自身で簡単にジョー成形が可能です。変種変量生産にも適しています。

*CE対応品

把握状態例

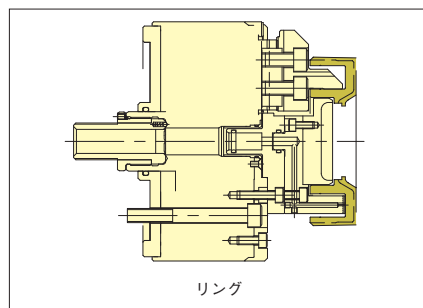

リング

■把握例

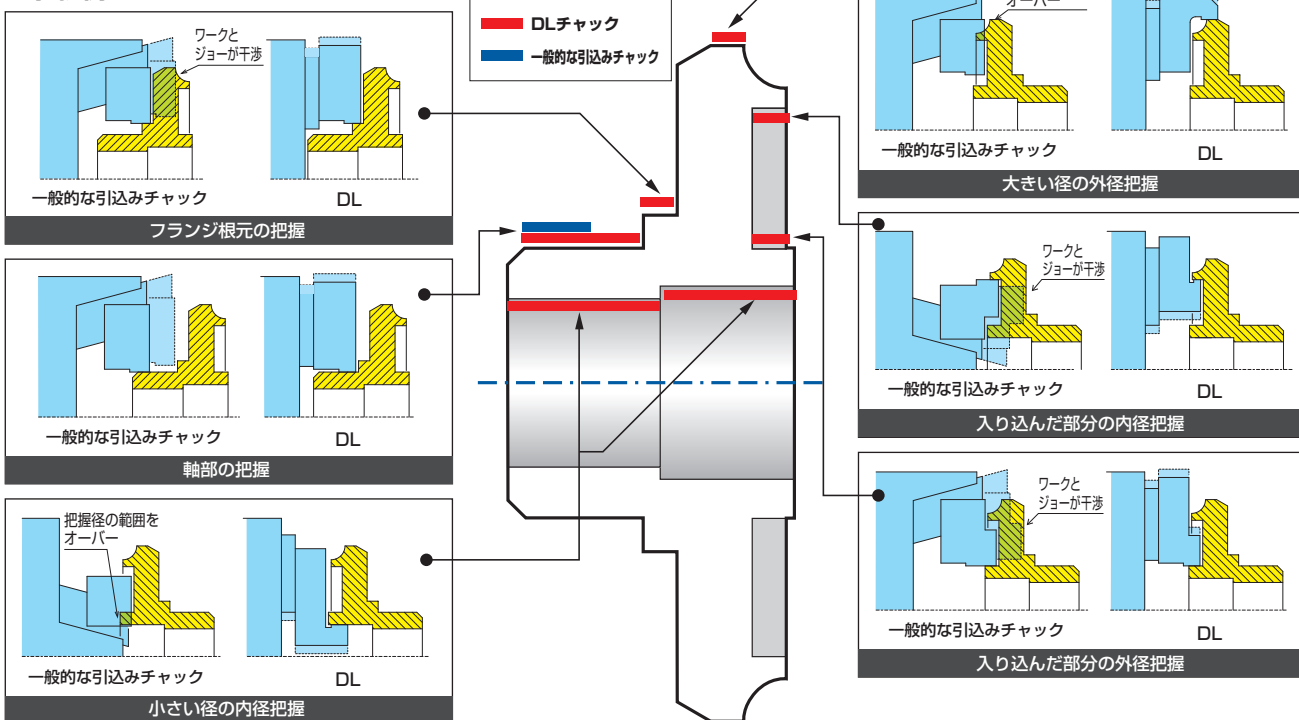

■ご使用上の注意

- ワークは端面をロケータに当てて把握してください。
- Tナットがマスタジョー端面から飛出した状態で使用しないでください。
- 外径把握と内径把握を切替える場合、カバーを取外しマスタジョーを180°回転させる必要があります。
- ワーク引込み量はワーク把握径、ジョーの剛性、ジョーの把握高さなど、把握する条件によって異なります。
引込みすぎてワークが歪んだり、引き込まなかったりする場合は、内部部品の調整、又は交換が必要になることがあります。その場合は弊社までご相談ください。
- 安定した把握や、引込みを得るためには、ジョーを低くして使用してください。
- チャック端面への追加加工はピン穴程度とし、カバーを貫通しないように注意してください。
- DL206のロケータ取付用ねじはカバー取付用ねじを使用してください。
- DL206・DL210にオプションジョーを使用する場合には、ジョーの追加加工が必要な場合があります。
- DL210のオプションジョーは、12inch用のSB112A1になります。ジョー形式の取違いに注意してください。
- 把握位置からアングルランプ位置までのジョーストローク量(片側)は次の値以上確保してください。
DL206: 0.7mm, DL208: 0.8mm, DL210: 1mm, DL212: 1mm
- その他、ご不明な点は弊社までご相談ください。

■ 寸法図

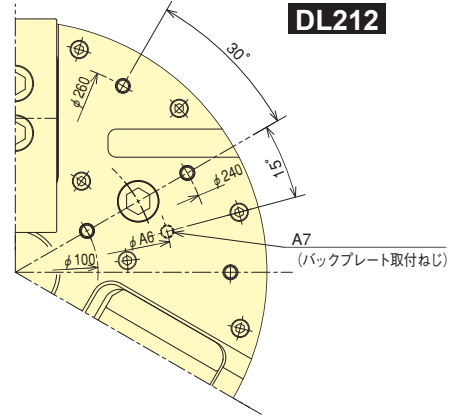
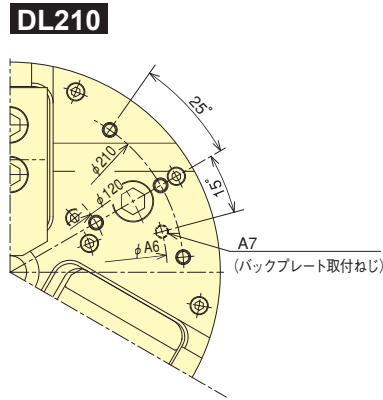
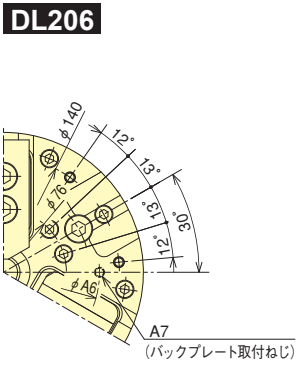
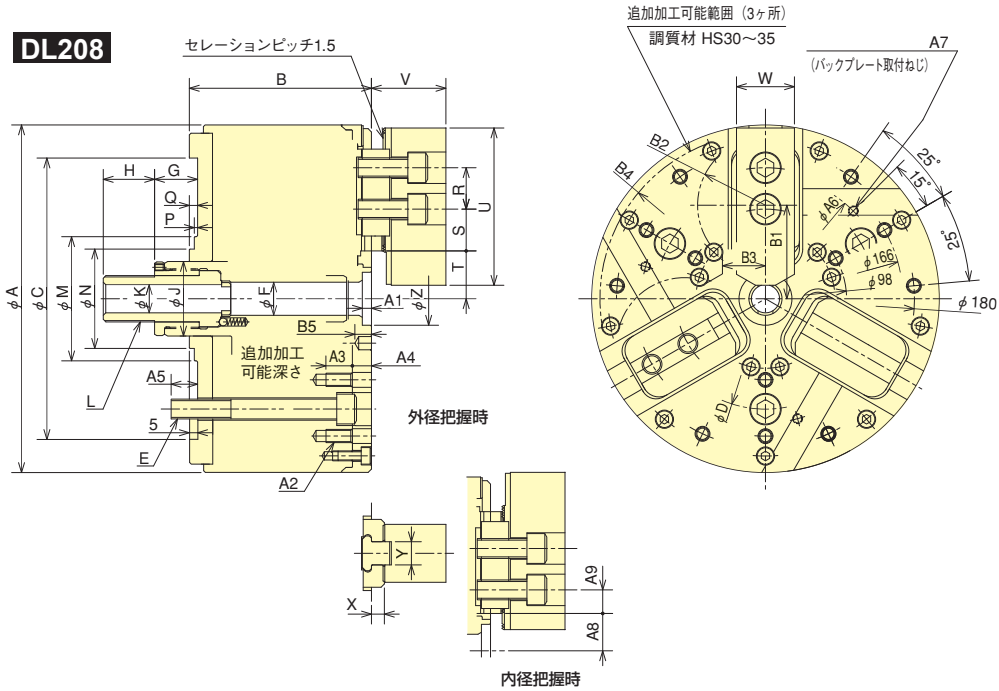

■ 寸法表

型式	A	B	C	D	E	F	G max.	G min.	H	J	K	L	M	N	P	Q	R	S max.	S min.	T max.	T min.
DL206	169	105	140	104.8	3-M10	20	34	22.5	30	42	17	M26×1.5	-	55	-	7	20	14.25	8.25	23.7	20.8
DL208	210	110	170	133.4	3-M12	20	37.5	26	31	45	17	M28×1.5	75	60	2	5	25	25.25	16.25	28.9	25.3
DL210	254	132	220	171.4	3-M16	20	38.5	24.5	39.5	50	17	M30×1.5	-	65	-	5	30	26.25	12.75	32.8	28.3
DL212	304	132	220	171.4	3-M16	50	33.5	19.5	44.5	75	17	M30×1.5	-	-	-	-	30	26.25	12.75	57.8	53.3

型式	U	V	W	X	Y	Z	A1	A2	A3	A4	A5	A6	A7	A8max.	A8min.	A9max.	A9min.	B1	B2	B3	B4	B5
DL206	72	41.5	31	10.3	12	32	4	3×7-M6	12	10.5	15	116	3-M6	23.7	20.8	21.25	15.25	47	R32	24	R79	MAX 9
DL208	95	45	35	7.8	14	32	5.5	3×4-M8	16	11.5	16	150	3-M6	26.2	22.6	20.25	11.25	56.5	R42	27	R100	MAX 10
DL210	101.5	59	45	14.7	18	35	5.5	3×4-M8	16	14	24	190	3-M8	29.7	25.2	35.25	21.75	68	R49	33	R120	MAX 12
DL212	129	64	50	14.7	18	50	14	3×4-M8	16	14	24	190	3-M8	54.7	50.2	35.25	21.75	93	R49	33	R145	MAX 12

■ 仕様表

型式	ジョーストローク (直径) mm	プランジャ ストローク mm	許容最大入力 kN(kgf)		最大静的把握力 kN(kgf)		許容最高 回転速度 min ⁻¹	質量 (標準ソフトジョー付) kg	慣性モーメント kg·m ²
			外径把握	内径把握	外径把握	内径把握			
DL206	5.8	11.5	19.0 (1937)	12.6 (1285)	54.0 (5506)	36.0 (3671)	6000	18.0	0.080
DL208	7.2	11.5	35.0 (3569)	23.0 (2345)	84.0 (8566)	56.0 (5710)	5000	30.0	0.135
DL210	9.0	14	50.0 (5099)	33.0 (3365)	110.0 (11217)	73.3 (7474)	4000	52.0	0.410
DL212	9.0	14	50.0 (5099)	33.0 (3365)	110.0 (11217)	73.3 (7474)	3000	74.0	0.880

型式	適合 シリンダ	許容最大油圧力 MPa(kgf/cm ²)		標準ジョー 使用時把握範囲 mm	標準ジョー 形式	オプションジョー 使用時把握範囲 mm	オプション ジョー形式	使用最低入力 kN(kgf)	使用最低油圧力 MPa(kgf/cm ²)
		外径把握	内径把握						
DL206	Y1020R/RE	2.70 (27.5)	1.70 (17.3)	φ25~φ140	SB06D1	φ25~φ158	SB06B1	5.0 (510)	0.9 (9.2)
DL208	Y1225R/RE	3.40 (34.7)	2.10 (21.4)	φ30~φ210	SB08B1	-	-	6.2 (632)	0.8 (8.2)
DL210	Y1530R/RE	3.40 (34.7)	2.30 (23.5)	φ40~φ234	SB10D1	φ40~φ254	SB12A1 (注9)	10.0 (1020)	0.9 (9.2)
DL212	Y1530R/RE	3.40 (34.7)	2.30 (23.5)	φ90~φ304	SB12A1	-	-	10.0 (1020)	0.9 (9.2)



CHUCK

Dual Lock Chuck

DL200 series

2-Way gripping

Unbelievable versatility with the ability to grip anything you want



● Increased gripping options

KITAGAWA introduce the worlds 1st chuck with two stage gripping action. Parallel jaw clamping with secondary pull back action for work-pieces seating. Jaws do not protrude in the Z Axis unlike conventional pull back chucks. This allows for improved gripping on difficult areas.

The gripping range is extended up the chuck OD allowing a wider range of work-pieces to be machined.

DL series contributes to improve the productivity by applying flexible chucking for various operations.

● Ideal for volume production machining

Dust proof sealed body design for long life. Suitable for automation and volume production.

● Easy jaw forming

Serrated Jaws are used allowing for easy jaw forming by customer.

*CE correspondence

Gripping Examples

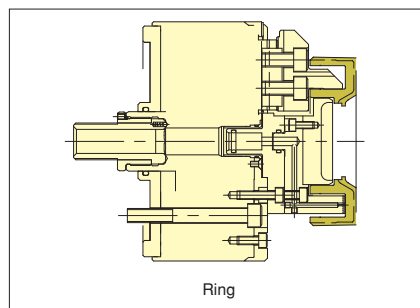

Ring

■ Example

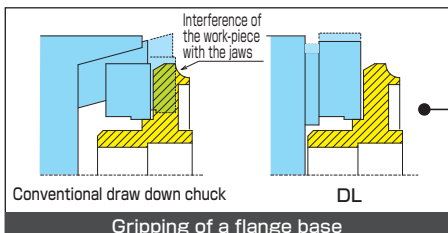

Gripping of a flange base

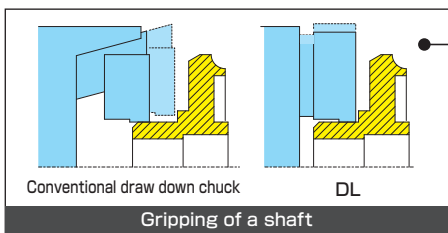

Gripping of a shaft

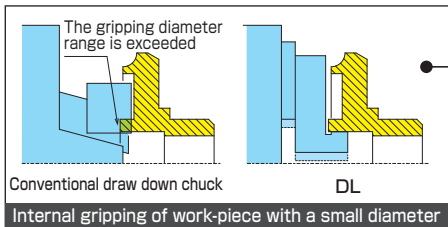

Internal gripping of work-piece with a small diameter

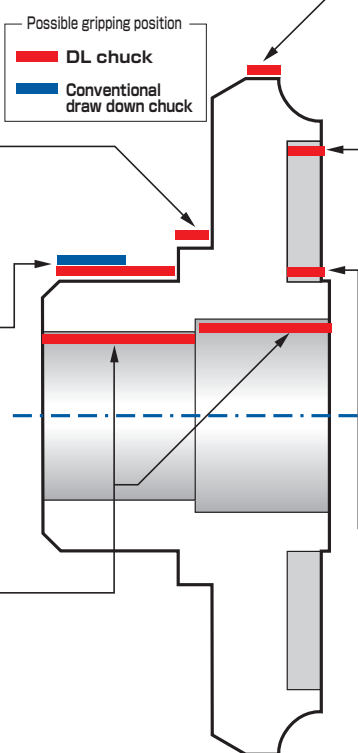

Possible gripping position
■ DL chuck
■ Conventional draw down chuck

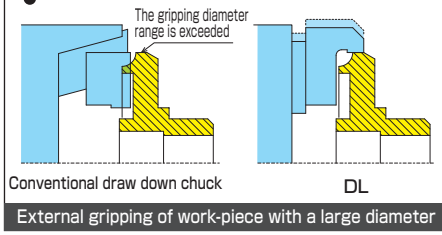

External gripping of work-piece with a large diameter

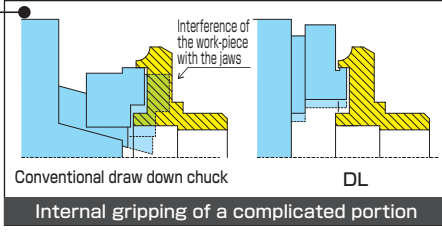

Internal gripping of a complicated portion

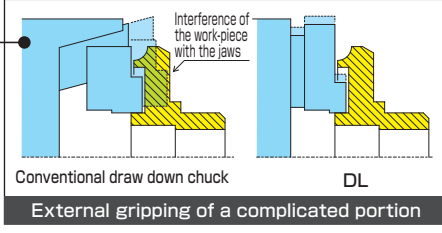

External gripping of a complicated portion

■ Precautions for operation

1. Attach a work-piece to a locator before gripping.
2. Do not use the chuck with a T-nut protruded from a master jaw end face.
3. When changing the method for gripping an inner diameter of the work-piece from an outer diameter of the work-piece, remove a cover in order to rotate the master jaw 180-degree.
4. A work-piece pulling quantity work-piece by gripping conditions such as the gripping diameter of the work-piece, stiffness of each jaw, jaw gripping height, etc. If the work-piece will be deformed due to over-pulling of the work-piece or vice versa, it is necessary to adjust parts or replace them. In this case, confer with our company.

5. To obtain a stable gripping and adequate pulling of the work-piece, set jaws low.
6. For additional machining to the chuck end face, a pin hole level is acceptable. Take care so as not to pass through the cover.
7. For locator mounting tap of DL206, use a cover mounting tap.
8. When using optional jaws for DL206 and DL210, the additional machining of jaws may be required.
9. Optional jaw of DL210 is SB12A1 of 12-inch. Take care so as not to use a wrong type of the jaw.
10. Refer to the amounts below for Jaw Stroke (one side) from the gripping position to the unclamping position.
DL206 : 0.7mm, DL208 : 0.8mm, DL210 : 1mm, DL212 : 1mm
11. Confer with our company about other unclear points.

アドバンスドチャック
Advanced Chuck

Dimensional Drawings

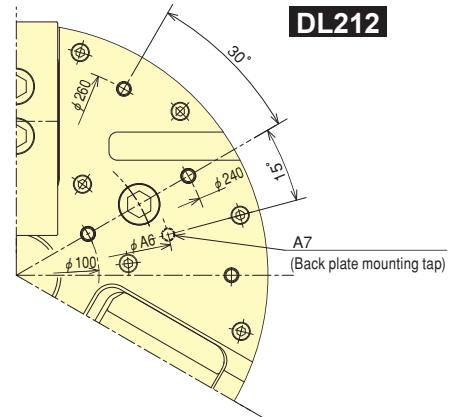
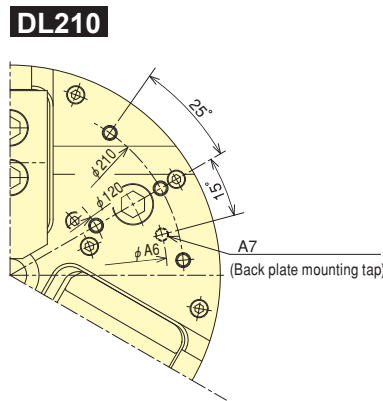
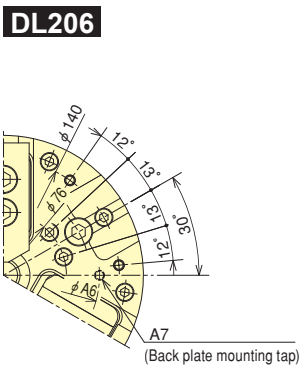
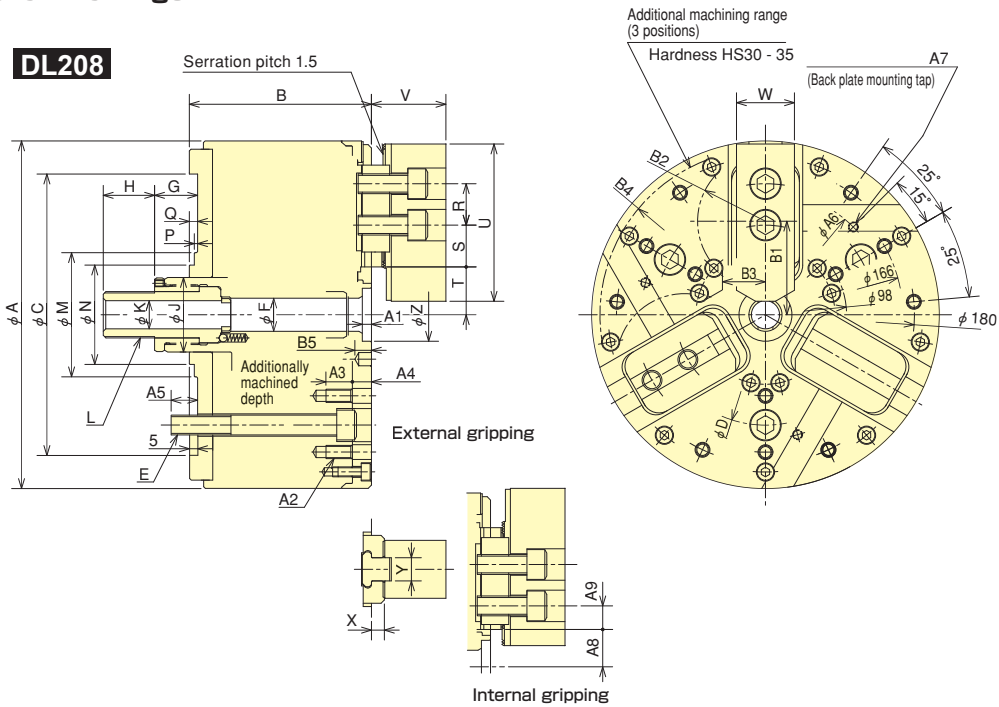

Dimensions

Model	A	B	C	D	E	F	G max.	G min.	H	J	K	L	M	N	P	Q	R	S max.	S min.	T max.	T min.
DL206	169	105	140	104.8	3-M10	20	34	22.5	30	42	17	M26×1.5	-	55	-	7	20	14.25	8.25	23.7	20.8
DL208	210	110	170	133.4	3-M12	20	37.5	26	31	45	17	M28×1.5	75	60	2	5	25	25.25	16.25	28.9	25.3
DL210	254	132	220	171.4	3-M16	20	38.5	24.5	39.5	50	17	M30×1.5	-	65	-	5	30	26.25	12.75	32.8	28.3
DL212	304	132	220	171.4	3-M16	50	33.5	19.5	44.5	75	17	M30×1.5	-	-	-	-	30	26.25	12.75	57.8	53.3

Model	U	V	W	X	Y	Z	A1	A2	A3	A4	A5	A6	A7	A8max.	A8min.	A9max.	A9min.	B1	B2	B3	B4	B5
DL206	72	41.5	31	10.3	12	32	4	3×7-M6	12	10.5	15	116	3-M6	23.7	20.8	21.25	15.25	47	R32	24	R79	MAX 9
DL208	95	45	35	7.8	14	32	5.5	3×4-M8	16	11.5	16	150	3-M6	26.2	22.6	20.25	11.25	56.5	R42	27	R100	MAX 10
DL210	101.5	59	45	14.7	18	35	5.5	3×4-M8	16	14	24	190	3-M8	29.7	25.2	35.25	21.75	68	R49	33	R120	MAX 12
DL212	129	64	50	14.7	18	50	14	3×4-M8	16	14	24	190	3-M8	54.7	50.2	35.25	21.75	93	R49	33	R145	MAX 12

Specifications

Model	Jaw Stroke (diameter) mm	Plunger Stroke mm	Max. Draw Bar Pull Force kN(kgf)		Max. Gripping Force kN(kgf)		Max. Speed min ⁻¹	Net Weight with Soft top jaws kg	Moment of inertia kg·m ²
			External gripping	Internal gripping	External gripping	Internal gripping			
DL206	5.8	11.5	19.0 (1937)	12.6 (1285)	54.0 (5506)	36.0 (3671)	6000	18.0	0.080
DL208	7.2	11.5	35.0 (3569)	23.0 (2345)	84.0 (8566)	56.0 (5710)	5000	30.0	0.135
DL210	9.0	14	50.0 (5099)	33.0 (3365)	110.0 (11217)	73.3 (7474)	4000	52.0	0.410
DL212	9.0	14	50.0 (5099)	33.0 (3365)	110.0 (11217)	73.3 (7474)	3000	74.0	0.880

Model	Matching Cylinder	Max. pressure MPa(kgf/cm ²)		Gripping range in standard jaw of use mm	Standard jaw type	Gripping range in optional jaw of use mm	Optional jaw type	Min. input kN(kgf)	Min. pressure MPa(kgf/cm ²)
		External gripping	Internal gripping						
DL206	Y1020R/RE	2.70 (27.5)	1.70 (17.3)	φ25~φ140	SB06D1	φ25~φ158	SB06B1	5.0 (510)	0.9 (9.2)
DL208	Y1225R/RE	3.40 (34.7)	2.10 (21.4)	φ30~φ210	SB08B1	-	-	6.2 (632)	0.8 (8.2)
DL210	Y1530R/RE	3.40 (34.7)	2.30 (23.5)	φ40~φ234	SB10D1	φ40~φ254	SB12A1 (Note 9)	10.0 (1020)	0.9 (9.2)
DL212	Y1530R/RE	3.40 (34.7)	2.30 (23.5)	φ90~φ304	SB12A1	-	-	10.0 (1020)	0.9 (9.2)