

Vise mounting examples on machining centres

Please refer to each dedicated catalogue for machine manufacturer in next page.

[Click to move to dedicated catalogues for machine manufactures](#)

◆ Typical vise mounting dimensions for machine table size

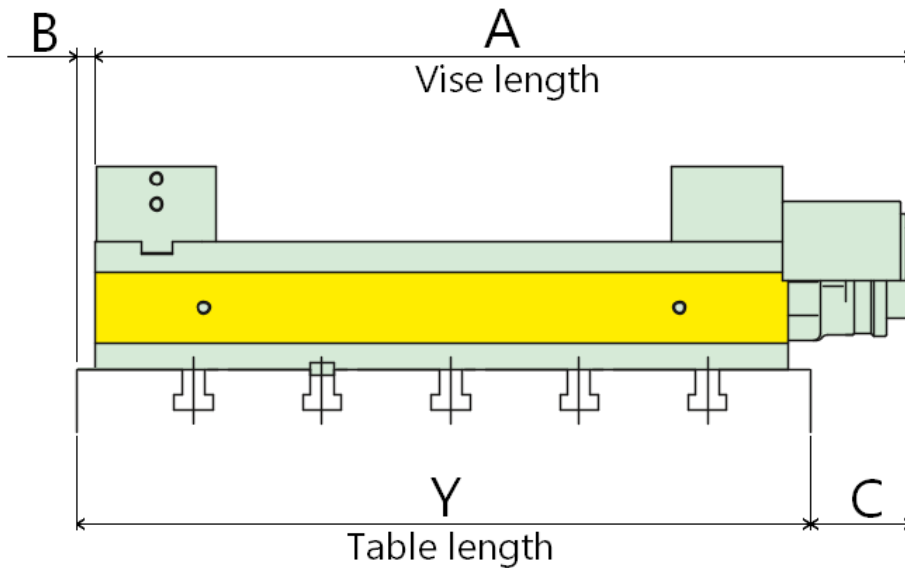
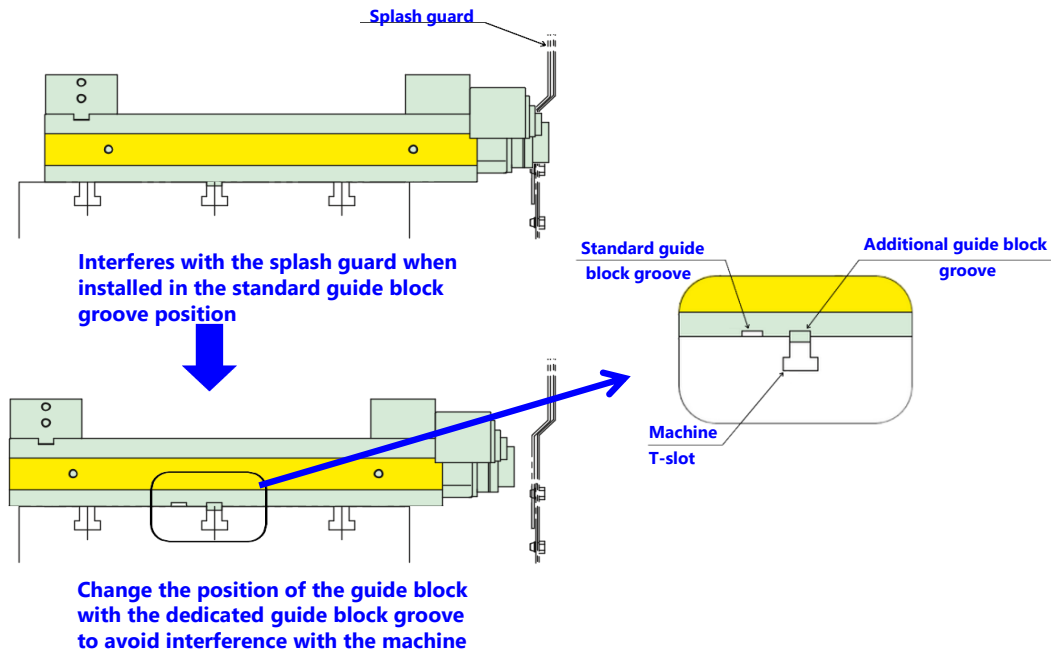

Table length Y	Number of T slots	Spacing of T-slots	Vise model	Vise length A	B	C	classifi- cation
330	3	125	VC103N	355.5	5	30.5	⊙
			VE125N	455	20	145	○
			VE125LN-**	510	0	180	△
400	3	100	VC104N	431.5	0	31.5	⊙
			VE125LN	510	0	110	○
			VE160N-**	555	0	155	△
460	3	150	VE125N-15	455	5	0	⊙
			VE125LN	510	30	80	○
			VE160N-**	555	0	95	△
460	4	100	VE125N	455	35	30	⊙
			VE125LN-**	510	0	50	△
			VE160N-**	555	0	95	△
560	4	125	VE200N	605	40.5	85.5	⊙
			VE160LN-**	635	0	75	△
560	5	100	VE200N	605	3	48	⊙
			VE200LN	710	3	153	○
600	6	100	VE200N	605	73	78	⊙
			VE160LN	635	73	108	○
			VE200LN-**	710	0	110	△
660	5	125	VE200LN	710	28	78	⊙

*This table is a rough guide when selecting a vise for the machining centre table size, and does not guarantee the suitability of the listed vise. Please consider the details for each machine specification.

The ones with ◎ in the classification column are the largest ones that can be installed without a large protrusion, the ones with ○ have a relatively large protrusion from the machine table but can be installed, the ones with △ ("-") is added at the end of the model number.) can be installed with the machine of the new guide block groove described later.

* If the vise interferes with the splash guard, it is possible to change the mounting reference position by additionally making the new guide block groove of the vise body to avoid interference. Please contact our sales office for the price and delivery.



*The guide block width and clamping device can be changed according to the T-slots of the mounting the mounting machine. Please contact our staff separately.

* If the handle interferes with the splash guard and the jaw cannot be tightened, use the optional extension bar or ratchet handle.

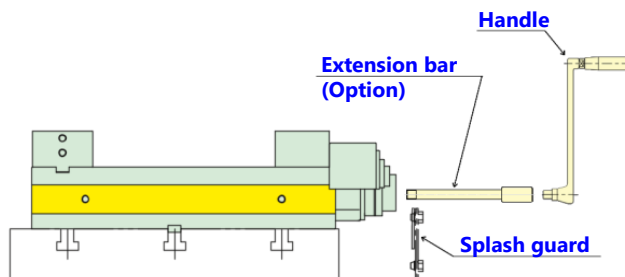

Dedicated catalogues for machine manufacturers

Click the brand name.

[Back to top](#)

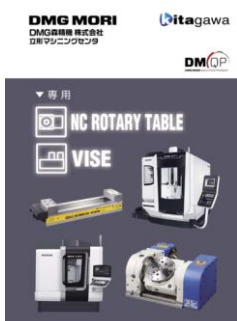

DMG Mori



Fanuc



Okuma



Yamazaki Mazak