



CHUCK

中実パワーチャック Closed Centre Power Chuck

N series

中実のスタンダードチャック The standard Closed Centre chuck

*CE対応品 *CE correspondence



■ 寸法図 Dimensional Drawings

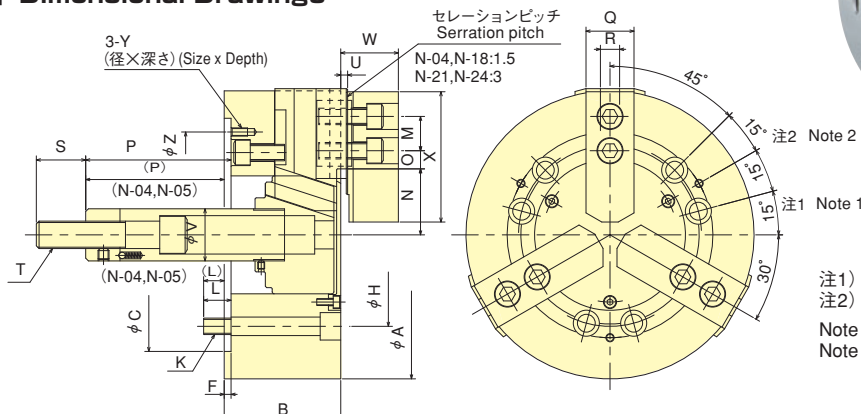

注1) N-21, 24の場合: 0°
注2) N-21, 24の場合: 60°
Note 1) N-21, 24 : 0°
Note 2) N-21, 24 : 60°

把握力性能曲線 Gripping Characteristic Graphs

※線は標準ソフトジョーを用いた場合のものです。 ※With standard blank soft top jaw.

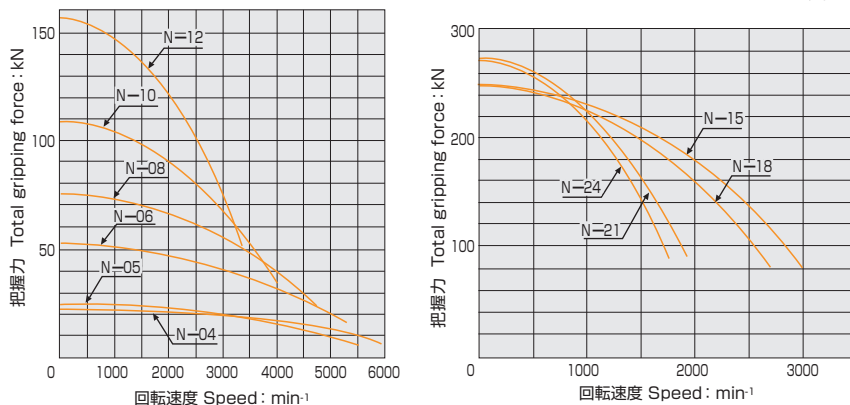

■ 寸法表 Dimensions

※N-04, 05の取付 120.ピッチー 3本 ※N-21, 24の取付 60.ピッチー 6本
※Mounting bolt P. C. D. for N-04 & N-05 : 120° pitch : 3 pcs. ※Mounting bolt P. C. D. for N-21 & N-24 : 60° pitch : 6 pcs.

型式 Model	A	B	C (H6)	F	H	J	K	L	M	N max.	N min.	O max.	O min.	P max.	P min.	Q	R	S	T	U	V	W	X	Y	Z
N-04	110	52	60	6	80	-	3-M8	12	14	23.3	20.1	11.25	8.25	18	3	23	10	25	M10	3	26	27	55	-	-
N-05	135	55	80	7	100	-	3-M8	14	19	30.4	27.2	11.25	6.75	9	-6	23	10	35	M12	3	28	29	62	-	-
N-06	165	74	140	5	104.8	21	6-M10	14	20	37.8	33.55	13.75	7.75	101.5	81.5	31	12	36	M16	4	34	35	72	M6×10	116
N-08	210	85	170	5	133.4	25	6-M12	20	25	46.3	41.9	22.25	11.75	127	106	35	14	36	M20	5	38	42	95	M6×12	150
N-10	254	89	220	5	171.4	34	6-M16	18	30	51.1	46.7	30.75	11.25	158	133	40	16	36	M20	5	45	46	110	M8×15	190
N-12	304	106	220	6	171.4	34	6-M16	18	30	61	55.75	48.75	12.75	163	133	50	18	36	M20	5	50	54	129	M8×15	190
N-15	381	114	300	6	235	-	6-M20	30	43	77.5	69.5	48.75	23.25	104	69	50	25.5	55	M30	2	60	61	135	M10×20	260
N-18	450	114	300	6	235	-	6-M20	30	43	108	100	48.75	23.25	92	57	50	25.5	55	M30	2	60	61	135	M10×20	260
N-21	530	125	380	6	330.2	-	6-M22	31	60	86	78	93.5	27.5	97	62	65	25	55	M30	3	60	71	180	M12×30	330.2
N-24	610	125	380	6	330.2	-	6-M22	31	60	125	117	93.5	27.5	97	62	65	25	55	M30	3	60	71	180	M12×30	330.2

※許容最高回転速度は、実測値によります ※N-24より大型については問い合わせ下さい。

■ 仕様表 Specifications

※Max. speed is shown using actual test data. ※For large type more than N-24, confer with KITAGAWA.
※把握径/把握範囲は標準のソフトジョーを使用した場合。 ※Gripping dia./gripping range is with standard soft jaws.

型式 Model	把握径 Gripping range mm		ジョーストローク(直径) Jaw Stroke(diameter) mm	プランジャストローク Plunger Stroke mm	許容最大入力 Max. Draw Bar Pull Force kN(kgf)	最大静的把握力 Max. Gripping Force kN(kgf)	許容最高回転速度 Max. Speed min ⁻¹	質量(標準ソフトジョー付) Net Weight with Soft top jaw kg	慣性モーメント Moment of inertia kg·m ²	適合シリンダ Matching Cylinder		許容最大油圧 Max. pressure MPa(kgf/cm ²)	適合ハードジョー 標準ソフトジョー Matching Hard top jaw Matching Soft top jaw	
	Max.	Min.								油圧 pressure	エア air		適合ハードジョー Matching Hard top jaw	標準ソフトジョー Matching Soft top jaw
N-04	110	6	6.4	15	82 (836)	228 (2325)	6000	4.1	0.008	Y0715R/RE	AY1315R	2.4 (24.5)	-	SJ04B1
N-05	135	16	6.4	15	82 (836)	25.2 (2570)	5500	6.2	0.015	Y0715R/RE	AY1315R	2.4 (24.5)	HBO5C1	SJ05B1
N-06	165	15	8.5	20	18 (1835)	52.5 (5353)	5270	13	0.045	Y1020R/RE	AY1720R	2.6 (26.5)	HBO6B1	SJ06B1
N-08	210	23	8.8	21	25 (2549)	75 (7648)	4760	25	0.138	Y1225R/RE	AY2225R	2.5 (25.5)	HBO8A1	SJ08B1
N-10	254	24	8.8	25	29 (2957)	108 (11013)	4010	37	0.300	Y1225R/RE	AY2225R	2.8 (28.6)	HB10A1	SJ10B1
N-12	304	26	10.5	30	41 (4181)	156 (15907)	3380	57.3	0.725	Y1530R/RE	-	2.7 (27.5)	HB12B1	SB12A1
N-15	381	72	16	35	82 (8362)	249 (25391)	3040	101	1.9	Y2035R/RE	-	3.2 (32.6)	HB15N1	SJ15N1
N-18	450	133	16	35	82 (8362)	249 (25391)	2710	126	3.3	Y2035R/RE	-	3.2 (32.6)	HB15N1	SJ15N1
N-21	530	69	16	35	82 (8362)	273 (27838)	1940	198	7.1	Y2035R/RE	-	3.2 (32.6)	HB18B2	SJ18A2
N-24	610	152	16	35	82 (8362)	273 (27838)	1760	252	12.0	Y2035R/RE	-	3.2 (32.6)	HB18B2	SJ18A2