



**ROTARY
CYLINDER**

中実回転油圧シリンダ Tandem Cylinder YW-R series

HWシリーズチャックに最適 Best suited for HW-series chucks

- YW-R ロックバルブ、リリーフバルブ付き
Built-in check valve and pressure relief valve
 - YW-RE ロックバルブ、リリーフバルブ、確認装置付き
Built-in check valve, pressure valve and sensor switches
- *YW-REのみ、CE対応品
*CE correspondence (YW-RE)

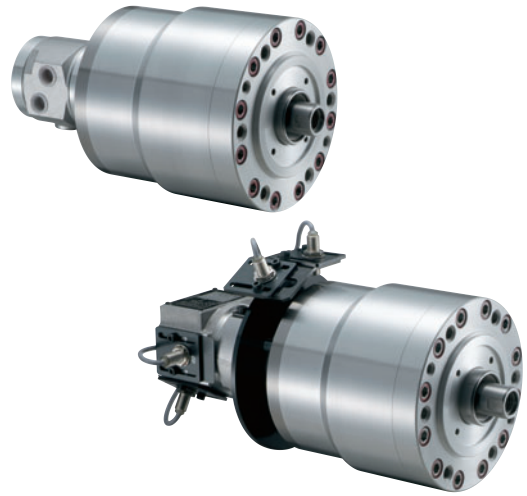

■ 寸法図 Dimensional Drawings

YW-R type

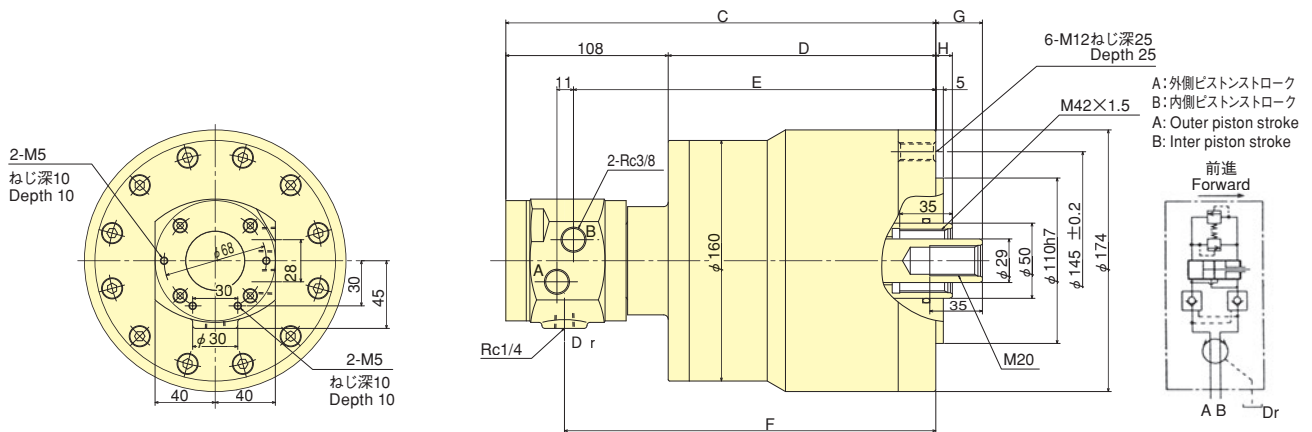

YW-RE type

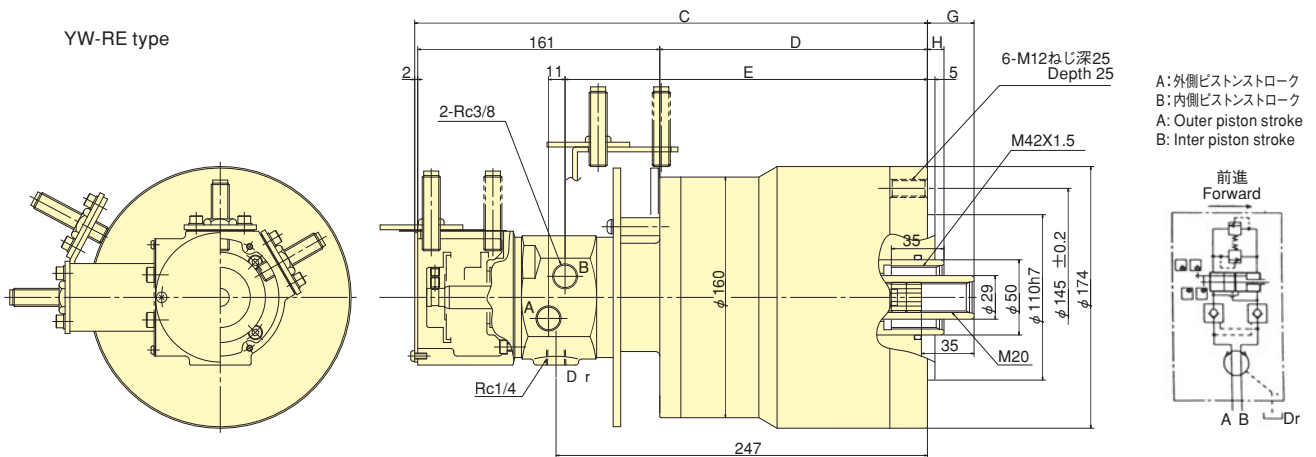

■ 寸法表 Dimensions

型式 Model	A	B	C	D	E	F	G max.	G min.	H max.	H min.
YW1220R	20	20	276	168	231	237	61	41	36	16
YW1225R	25	25	286	178	241	247	56	31	36	11
YW1220RE	20	20	331	168	231	237	61	41	36	16
YW1225RE	25	25	341	178	241	247	56	31	36	11

■ 仕様表 Specifications

*ピストン推力：油圧力3.0MPa(30.6kgf/cm²) *ドレン量は油圧力3.0MPa(30.6kgf/cm²)、油温50℃の時
*Draw bar pull force : Pressure 3.0MPa (30.6kgf/cm²) *Leakage : 3.0MPa (30.6kgf/cm²) and oil temperature 50℃.

仕様 型式 Model	ピストンストローク Piston stroke mm	ピストン表面積 Piston Area cm ²	ピストン推力 Draw bar pull force kN(kgf)	最高使用油圧力 Max. Operation Pressure MPa(kgf/cm ²)	ドレン量 Leakage ℓ / min	許容最高回転速度 Max. Speed min ⁻¹	質量 Net Weight kg	慣性モーメント Moment of inertia kg·m ²
YW1220R	20	126	33.0 (3365)	3.0 (30.6)	0.7	5000	15.3	0.043
YW1225R	25	126	33.0 (3365)	3.0 (30.6)	0.7	5000	15.5	0.044
YW1220RE	20	123	32.0 (3263)	3.0 (30.6)	0.7	5000	16.3	0.044
YW1225RE	25	123	32.0 (3263)	3.0 (30.6)	0.7	5000	16.5	0.045