



CHUCK

インディペンデントチャック (ショートテーパ) Independent Chuck (Short Taper) IA series

4爪単動のKITAGAWAスタンダードタイプ Independent 4 Jaw Chuck

- バックプレートなしで、直接取り付けできるショートテーパ用チャックです
Chuck for short taper that can be directly mounted without back plate

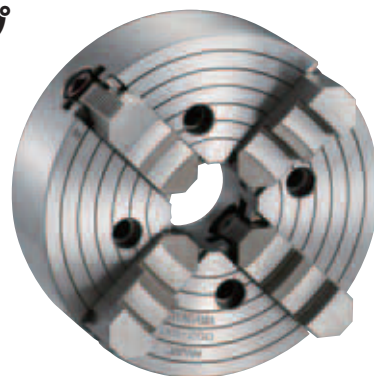

■ 寸法図 Dimensional Drawings

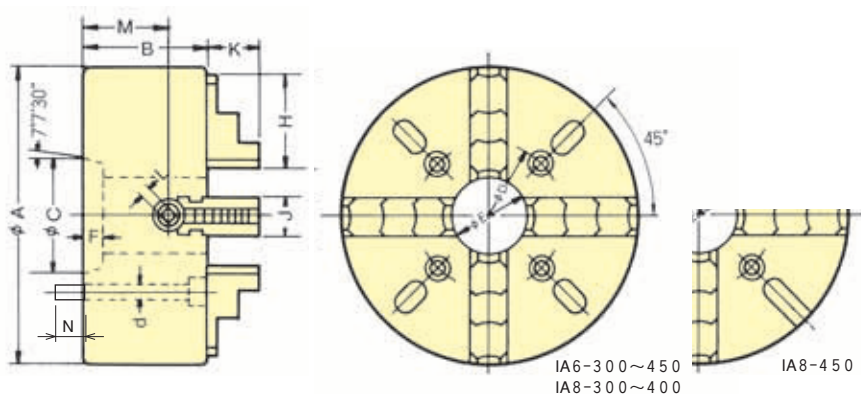

(注) IA5-200とIA6-250にはチャック表面のT溝はありません。
(Note) No T slot on the chuck surface for IA5-200 and IA6-250.

■ 寸法表 Dimensions

主軸端呼び Spindle Nose	型式 Type	寸法 Size	A	B	C	D	E	F	H	J	K	L	M	N	(取付ボルト) (Mounting bolt)	dの本数 Number of mounting bolts
A2- 5	IA 5 -200		200	70	82.563	104.8	50	15	75	30	30	10	38.5	17	M10×75	4
	IA 6 -250		250	77	106.375	133.4	55	17	90	30	35	10	44.5	17	M12×80	4
A2- 6	IA 6 -300		300	90	106.375	133.4	65	17	100	35	40	12	53	19	M12×95	4
	IA 6 -350		350	90	106.375	133.4	75	17	110	35	45	12	53	19	M12×95	4
	IA 6 -400		400	100	106.375	133.4	75	17	120	40	50	14	58.5	17	M12×100	4
	IA 6 -450		450	105	106.375	133.4	80	17	130	40	55	14	63.5	20	M12×110	8
A2- 8	IA 8 -300		300	100	139.719	171.4	75	18.5	120	40	50	14	58.5	24	M16×105	4
	IA 8 -350		350	100	139.719	171.4	75	18.5	120	40	50	14	58.5	24	M16×105	4
	IA 8 -400		400	105	139.719	171.4	90	18.5	120	40	50	14	58.5	24	M16×110	4
	IA 8 -450		450	105	139.719	171.4	100	18.5	130	40	55	14	63.5	24	M16×110	4

■ 仕様表 Specifications ※IA-6-450の取付 45°ピッチ-8本 ※Mounting of IA-6-450 : 45° pitch, 8 pcs.

主軸端呼び Spindle Nose	型式 Type	仕様 Spec. 貫通穴径 Thru-Hole mm	最大静的把握力 Max. Gripping Force		最大把握径 Max. Gripping dia.		最少把握径 Min. Gripping dia.		チャック Chuck		
			ハンドルトルク Handle torque N·m(kgf·m)	ジョー1個締付力 Tightening force of a jaw kN(kgf)	内爪 Inner jaw φmm	外爪 Outer jaw φmm	内爪 Inner jaw φmm	内爪 Inner jaw φmm	質量 Net Weight kg	慣性モーメント Moment of inertia kg·m ²	許容最高回転速度 Max. Speed min ⁻¹
A2- 5	IA 5 -200	50	83.0 (8.5)	10.0(1020)	75	185	14	14.9	0.080	3600	
	IA 6 -250	55	118.0 (12.0)	15.0(1530)	95	220	14	24.2	0.188	3000	
A2- 6	IA 6 -300	65	147.0 (15.0)	16.0(1632)	125	265	18	39.1	0.400	2000	
	IA 6 -350	75	147.0 (15.0)	16.0(1632)	155	310	20	50.9	0.750	2000	
	IA 6 -400	75	216.0 (22.0)	20.0(2039)	190	360	30	69.8	1.175	1800	
	IA 6 -450	80	245.0 (25.0)	23.0(2345)	220	405	35	97.2	1.775	1200	
A2- 8	IA 8 -300	75	147.0 (15.0)	16.0(1632)	125	265	18	39.1	0.400	2000	
	IA 8 -350	75	216.0 (22.0)	20.0(2039)	155	310	20	56.2	0.775	2000	
	IA 8 -400	90	245.0 (25.0)	23.0(2345)	190	360	30	73.8	1.250	1800	
	IA 8 -450	100	245.0 (25.0)	23.0(2345)	220	405	35	102.5	1.825	1200	