



WORK GRIPPER

パワーウイングワークグリッパ PWS06

旋盤用チャックがM/C用に変身 シリンダ内蔵でコストダウン

- ワーク素材を引き込む安定把握
旋盤工程前後の荒加工用に使用すれば、同じ把握状態で省段取り
- シリンダ内蔵で導入コストダウン *別途チャック作用用シリンダが不要です
- 機械標準コラム仕様で対応可能 *シリンダ内蔵で全高を低く抑えました
- NC円テーブルにスムーズ搭載



■ 寸法図

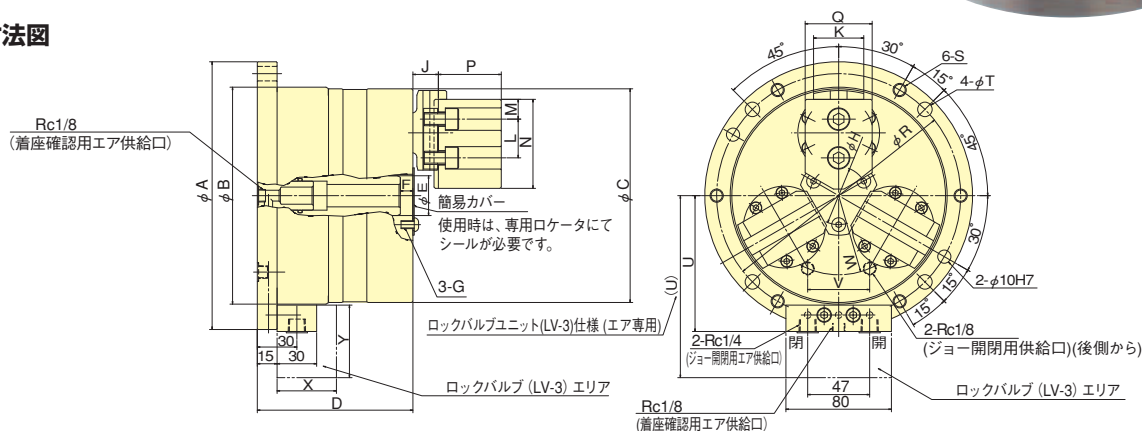

■ 寸法表

※(U),X,Yの寸法はLV-3(ロックバルブ)の寸法である。

寸法	A	B	C	D	E	F	G	H	J	K	L	M	N	P	Q	R	S	T	U	(U)	V	W	X	Y
型式	h7				+0.02 0	min	M6 深12									(±0.2)								
PWS06	203	164.5	162	118	30.17	5.5		44	19.3	38.07	29.36	15	67.5	47.7	50.8	185	M10	11	103	138	47	60	45	55

■ 仕様表

※把握力はジョーおよびワークの把握部状態により変化します。 ※空気消費量はプランジャストローク5mm当たり、圧力0.6MPa時

型式	仕様	プランジャストローク mm	ジョーストローク (直径) mm	把握力 kN(kgf)		許容最大圧力 MPa(kgf/cm ²)		最低使用圧力 MPa(kgf/cm ²)		把握径 mm				質量 (標準ソフトジョー付) kg	空気消費量 (N _l)
				エア圧力 0.6MPa (6kgf/cm ²)	油圧力 1.3MPa (13kgf/cm ²)	エア圧力	油圧力	外径 φ		内径 φ					
								Max.	Min.	Max.	Min.				
PWS06		11.1	7.7	19 (1937)	53 (5404)	0.7 (7)	1.3 (13)	0.2 (2)	120	13	160	70	24	0.54	

■ 作動位置寸法図 (外径把握時)

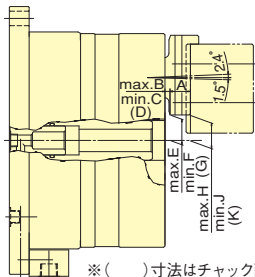

※()寸法はチャック面とソフトジョートリツケ面が平行の場合を示す。

■ 作動位置寸法表 (外径把握時)

寸法	A	B	C	D	E	F	G	H	J	K
型式										
PWS06	15.50	4.96	3.05	3.80	20.06	18.89	19.33	20.70	18.48	19.33

■ 作動位置寸法図 (内径把握時)

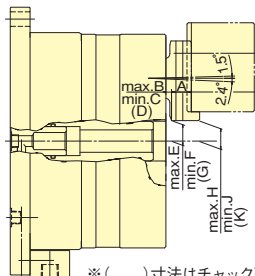

※()寸法はチャック面とソフトジョートリツケ面が平行の場合を示す。

■ 作動位置寸法表 (内径把握時)

寸法	A	B	C	D	E	F	G	H	J	K
型式										
PWS06	15.03	5.59	3.43	4.27	16.28	15.08	15.53	17.17	14.52	15.53



WORK GRIPPER

Power Wing Work Gripper PWS06

Suitable for 3 to 5-Axis machines

Cost reduction achieved by built-in Cylinder

- Stationary clamping by pull back the workpiece
Suitable for rough machining, OP-10 or OP-20 with reduced setup time.
- Cost reduction achieved by built-in Cylinder
*No need to introduce separated Cylinder for Chuck.
- Available on the standard column of machine
*Total height is reduced by built-in Cylinder.
- Available to be mounted on NC Rotary Table



Dimensional Drawings

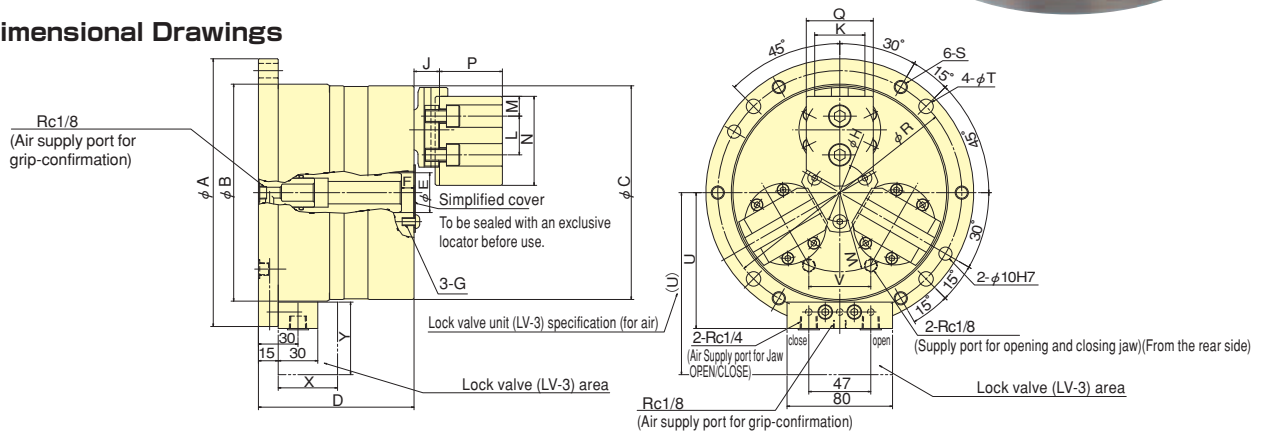

Dimensions ※The dimensions of (U)/X/Y marked are the size of LV-3(Lock-valve).

Dimensions	A	B	C	D	E	F	G	H	J	K	L	M	N	P	Q	R	S	T	U	(U)	V	W	X	Y
Model	h7				$+0.02$ 0	min	M6 Depth 12									(± 0.2)								
PWS06	203	164.5	162	118	30.17	5.5		44	19.3	38.07	29.36	15	67.5	47.7	50.8	185	M10	11	103	138	47	60	45	55

Specifications ※Clamping force varies in clamping state for jaws and workpiece. ※Air Consumption = Under Pressure 0.6MPa Plunger Stroke per 5mm

Specifications	Plunger Stroke mm	Jaw Stroke (diameter) mm	Gripping Force kN(kgf)		Max. allowable pressure MPa(kgf/cm ²)		Min. allowable pressure MPa(kgf/cm ²)	Gripping range mm				Net Weight with Soft top jaws kg	Air consumption (N ℓ)
			Pneumatic at 0.6MPa (6kgf/cm ²)	Hydraulic at 1.3MPa (6kgf/cm ²)	Pneumatic	Hydraulic		external ϕ		Internal ϕ			
Model								Max.	Min.	Max.	Min.		
PWS06	11.1	7.7	19 (1937)	53 (5404)	0.7 (7)	1.3 (13)	0.2 (2)	120	13	160	70	24	0.54

Dimensional Drawing for actuated position (External Gripping)

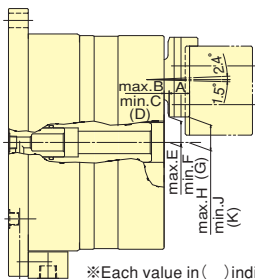

※Each value in () indicate that surface of chuck and Jaw mounting side is parallel.

Dimensions for actuated position (External Gripping)

Dimensions	A	B	C	D	E	F	G	H	J	K
Model										
PWS06	15.50	4.96	3.05	3.80	20.06	18.89	19.33	20.70	18.48	19.33

Dimensional Drawing for actuated position (Internal Gripping)

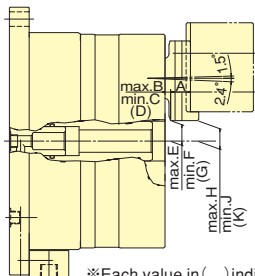

※Each value in () indicate that surface of chuck and Jaw mounting side is parallel.

Dimensions for actuated position (Internal Gripping)

Dimensions	A	B	C	D	E	F	G	H	J	K
Model										
PWS06	15.03	5.59	3.43	4.27	16.28	15.08	15.53	17.17	14.52	15.53

ワークグripper
Work Gripper