

スピンドル穴  
SPINDLE THRU-HOLE

仕様 SPECIFICATIONS	
削出精度 INDEXING ACCURACY	20 sec以内
再現精度 REPEATABILITY	4 sec以内
テーブル最高回転速度 MAXIMUM ROTATION SPEED	50 min <sup>-1</sup> (モータ) 3000 min <sup>-1</sup> (モータ)
クランプトルク CLAMPING TORQUE	150N·m
許容最大空圧力 MAXIMUM PNEUMATIC PRESS	0.7 MPa
許容積載質量 ALLOWABLE MASS OF WORK	機HORZ 120 kg 立VERT 60 kg
許容積載ワーク径 ALLOWABLE WORK DIA.	φ128 mm
総減速比 TOTAL REDUCTION RATIO	1/60
製品質量 MASS OF ROTARY TABLE	33 kg
駆動系モーメント慣性モーメント MACHINE INERTIA (REFER TO MOTOR SHEET)	0.00004kg·m <sup>2</sup>

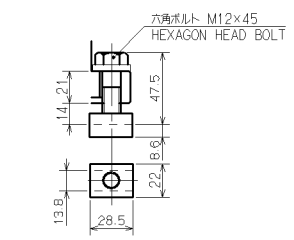

クランプ器具 付属品 2組  
CLAMPING PARTS ACCESSORY 2 PAIR

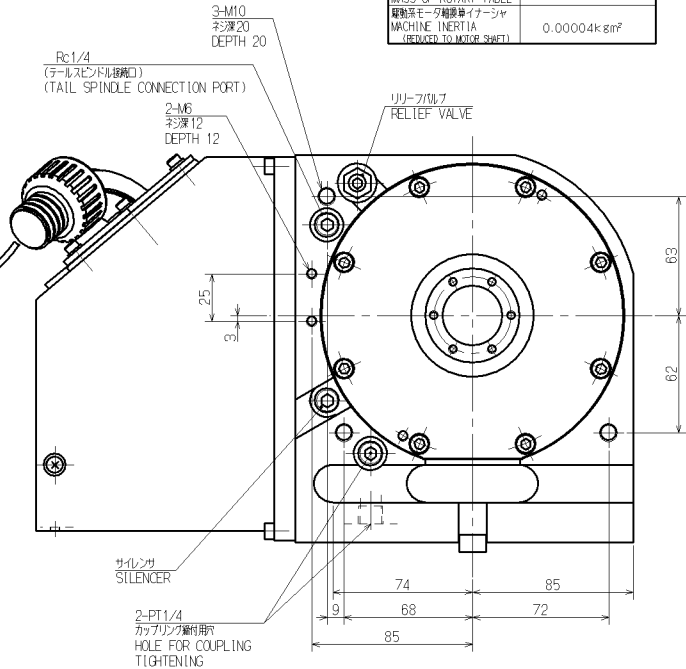
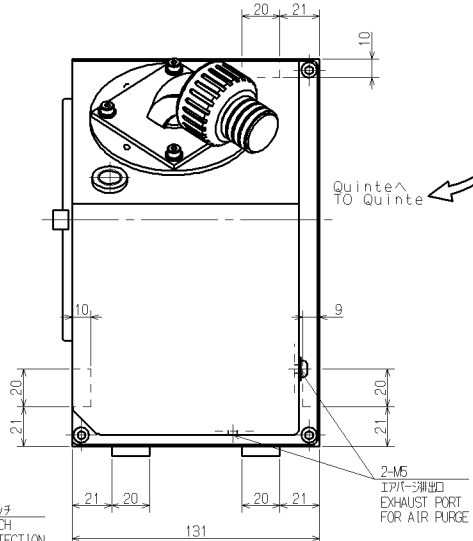
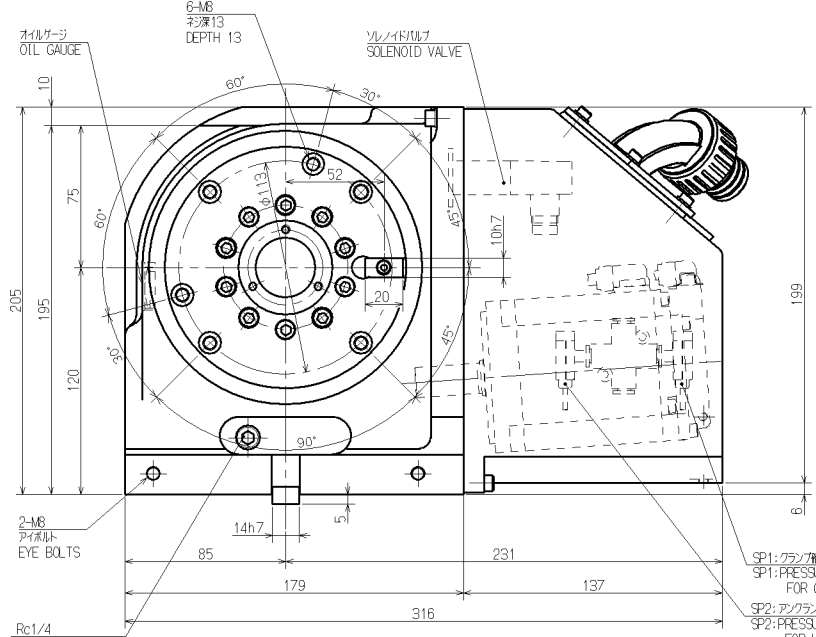
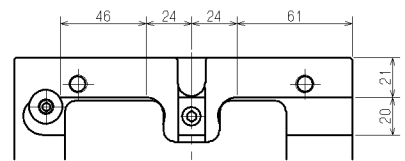
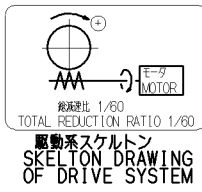

CAREER	SCALE	TYPE	MR120RAV00	WEIGHT	kg
MANAGER	1:2	NAME	NCテーブル NC ROTARY TABLE		
CHIEF	3RD ANGLE	NAME	MR120RAV00 ガイケイ		
DRAWN BY		DRW NO.	61E 26 9960		
KITAGAWA IRON WORKS CO.,LTD.	DATE				