

スピンドル穴
SPINDLE THRU-HOLE

仕様 SPECIFICATIONS	
割出精度 INDEXING ACCURACY	50 sec以内
再現精度 REPEATABILITY	10 sec以内
テーブル最高回転速度 MAXIMUM ROTATION SPEED	83.3 min ⁻¹ (モータ MOTOR 3000 min ⁻¹)
クランプトルク CLAMPING TORQUE	80N・m (0.5MPa) (空気圧 AIR PRESS)
許容最大空圧力 MAXIMUM PNEUMATIC PRESS	0.7 MPa
許容積載質量 ALLOWABLE MASS OF WORK	横 hor 60 kg 立 vert 30 kg
許容積載ワーク径 ALLOWABLE WORK DIA.	φ105 mm
総減速比 TOTAL REDUCTION RATIO	1/36
製品質量 MASS OF ROTARY TABLE	23 kg
慣性モーメント (ワーク含まず) MACHINE INERTIA (EXCLUDING TO WORK 30kg)	0.00003kg・m ²

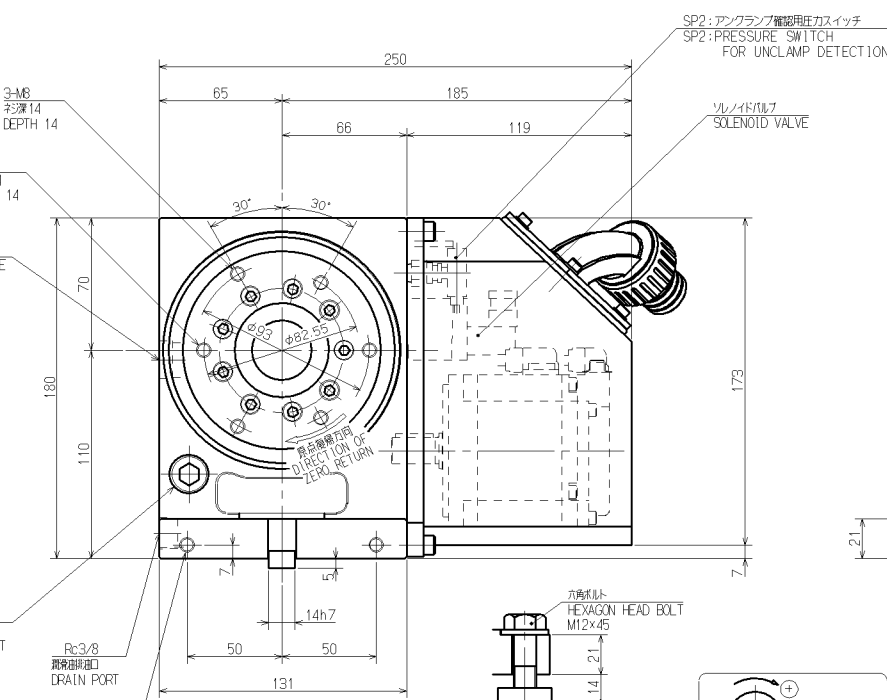

クランプ器具 付属品 2組
CLAMPING PARTS ACCESSORY 2 PAIR

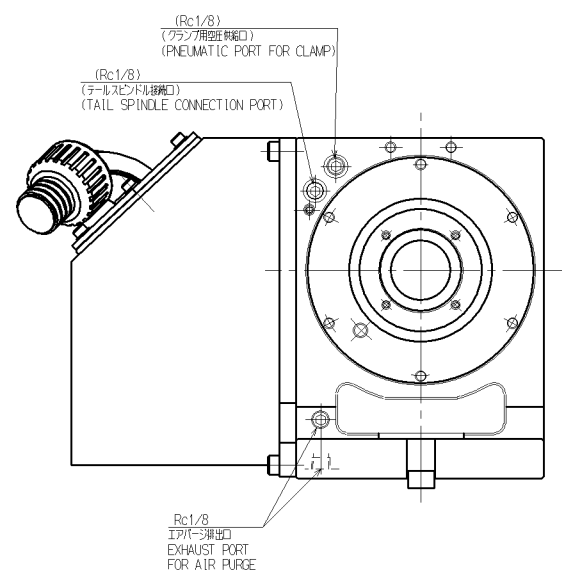
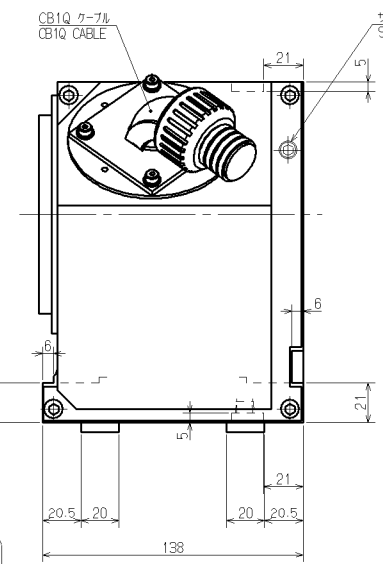

CAREER	SCALE	TYPE	RS100RAV00	WEIGHT	kg
MANAGER	1:2	NCテーブル	NC ROTARY TABLE		
CHIEF	3RD ANGLE	NAME	RS100RAV00	ガイガイ	OUTSIDE VIEW
DRAWN BY	DATE	DRW NO.	61E 27 0000		0
KITAGAWA IRON WORKS CO.,LTD.					