

仕様 SPECIFICATIONS	
引出精度 INDEXING ACCURACY	20 sec以内
再現精度 REPEATABILITY	4 sec以内
テーブル最高回転速度 MAXIMUM ROTATION SPEED	16.6 min ⁻¹ (1000 rev/min)
クランプトルク CLAMPING TORQUE	2000N-m (180kgf-m)
許容最大空圧力 MAXIMUM PNEUMATIC PRESS.	0.6 MPa
許容積載質量 ALLOWABLE MASS OF WORK	180 kg
許容ワーク径 ALLOWABLE WORK DIA.	φ320 mm
総減速比 TOTAL REDUCTION RATIO	1/180
製品質量 MASS OF ROTARY TABLE	223 kg
慣性モーメント (モーターに接続時) MACHINE INERTIA (INDEXED TO MOTOR SHFT)	0.000640kgm ²

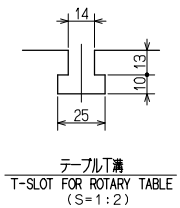

スピンドル穴 SPINDLE THRU-HOLE

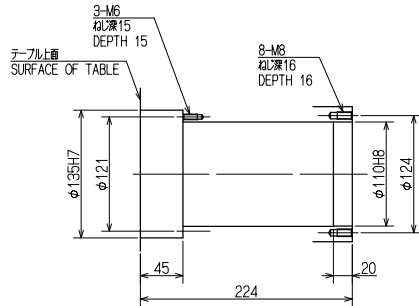
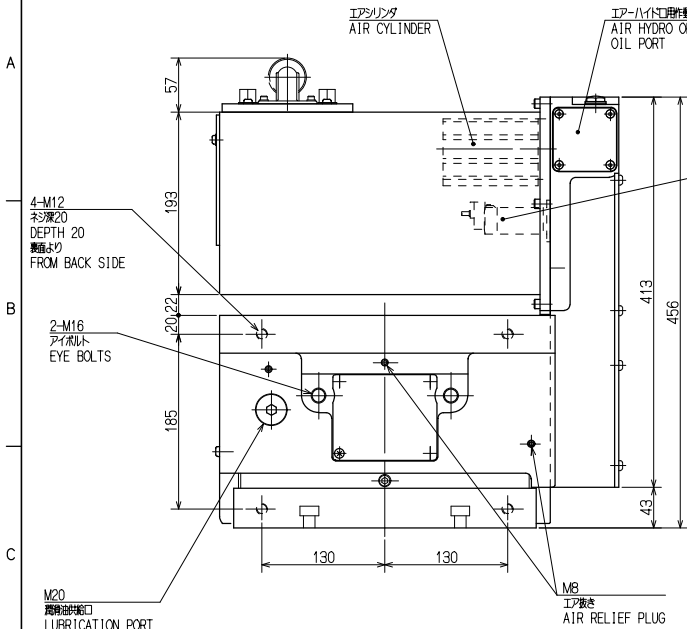
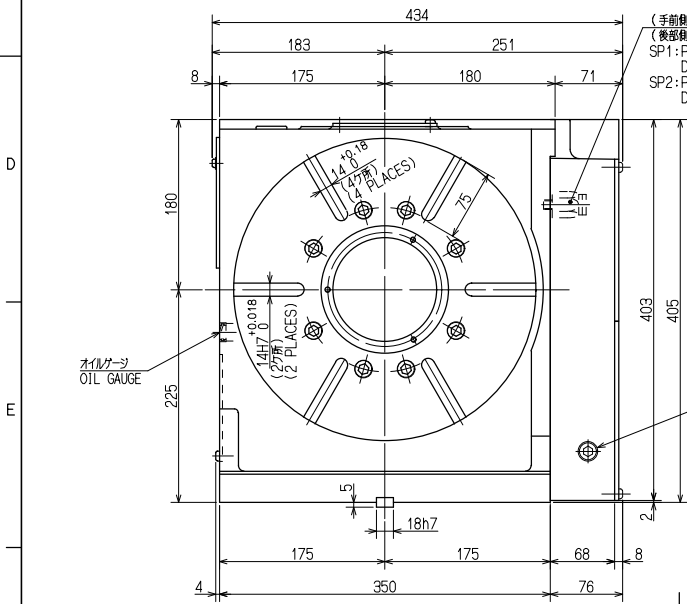

(手前側) SP1: クランプ確認用圧カススイッチ (後側側) SP2: アンクランプ確認用圧カススイッチ
 SP1: PRESSURE SWITCH FOR CLAMP DETECTION ON THIS SIDE
 SP2: PRESSURE SWITCH FOR UNCLAMP DETECTION ON BACK SIDE

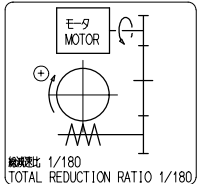
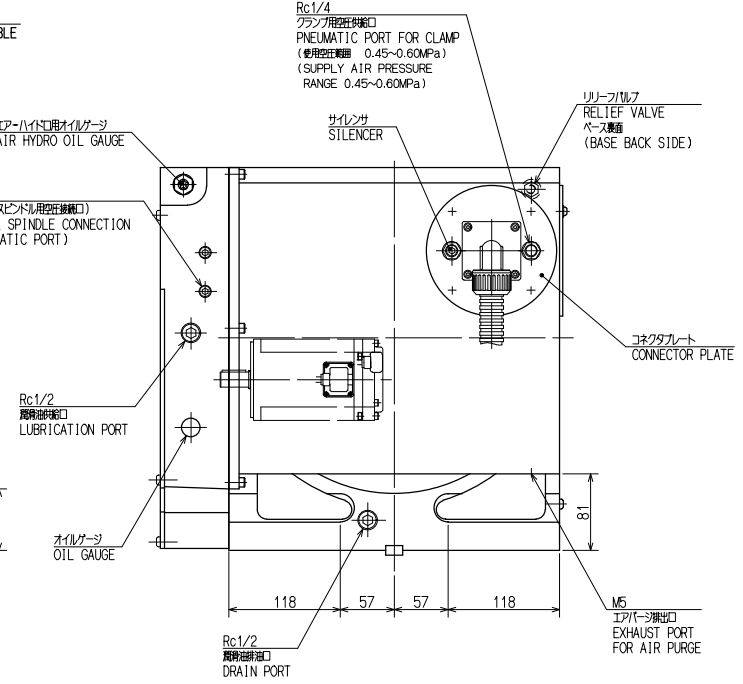
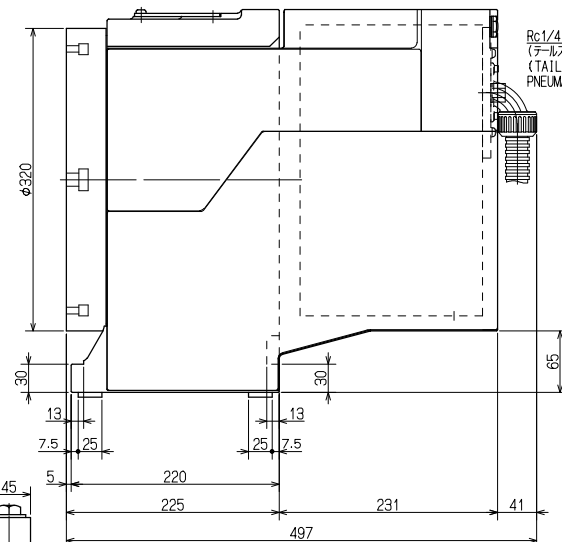

駆動系スケルトン SKELTON DRAWING OF DRIVE SYSTEM

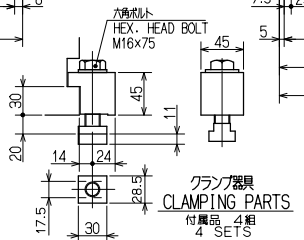

CAREER			SCALE	TYPE	TBX320BV00	WEIGHT	kg
W. D.			1:4	NCテーブル NC ROTARY TABLE			
MANAGER	CHIEF	DRAWN BY	3RD ANGLE	NAME	TBX320BV00 ガイケイ OUTSIDE VIEW		
KITAGAWA IRON WORKS CO., LTD.		DATE		DRW NO.	61E274781		