

追加加工範囲  
(3ヶ所)  
調質材 HS30~35  
SHADED AREA: IT IS POSSIBLE  
TO BORE OR TAP ADDITIONALLY  
(3PLACES)  
HEAT-REFINING HS30-35

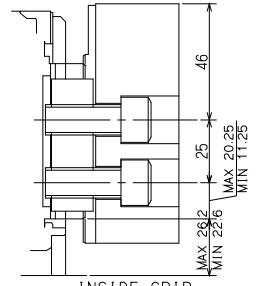
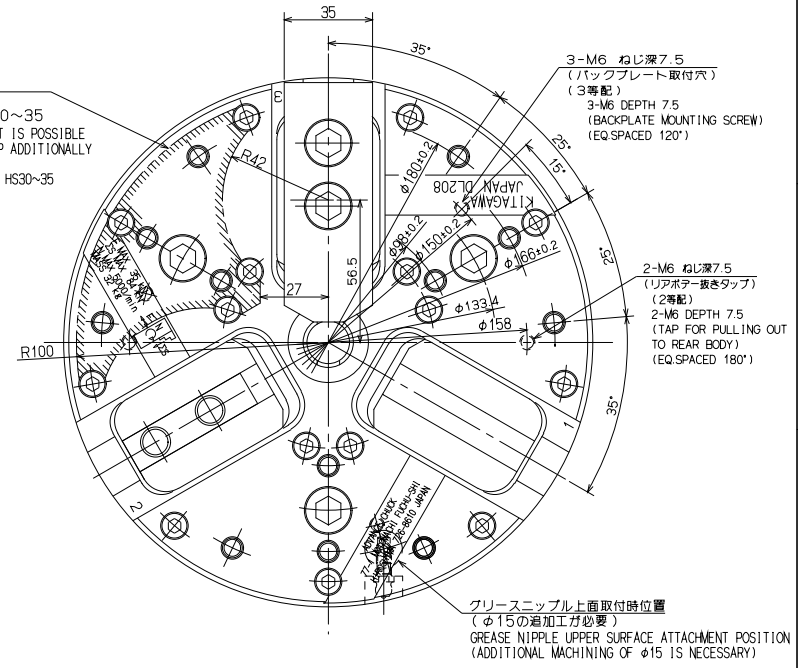

SPECIFICATIONS (OUTSIDE GRIP)		仕 様		外 径 把 握 時	
PLUNGER STROKE プランジャストローク	11.5	mm			
JAW STROKE (IN DIA) ジョーストローク(直径で)	7.2	mm	INSIDE GRIP ※内径把握時		
MAX PERMISSIBLE INPUT FORCE 許容最大入力	35 (3569 kgf)	kN	23 (2379 kgf)		
MAX STATIC GRIPPING FORCE 最大静的把握力	84 (8566 kgf)	kN	56 (5710 kgf)		
MAX PERMISSIBLE SPEED 許容最高回転速度	5000	min <sup>-1</sup>			
MASS 質量	30	kg			
MOMENT OF INERTIA 慣性モーメント	0.135	Kg·m <sup>2</sup>			
DYNAMIC GRIPPING FORCE AT MAX SPEED 最高回転時の動的把握力	28 (2855 kgf)	kN			
OPERATING CYLINDER 使用シリンダ	Y1225R		INSIDE GRIP ※内径把握時		
MAX PERMISSIBLE OIL PRESS 許容最大油圧	3.4 (34.7 kgf/cm <sup>2</sup> )	MPa	2.1 (21.4 kgf/cm <sup>2</sup> )		
MINIMUM OPERATING INPUT FORCE (OIL PRESS 0.8MPa) AS USE THE STANDARD CYLINDER/ 最低使用入力 (標準シリンダでは 油圧力 0.8MPa)	6.2 (628 kgf)	kN			

上記仕様は許容最大入力時の場合  
(また最大静的把握力、および許容最高回転速度については  
セレーション上面から19mmの高さでの(実測)値を示す)  
内径把握時の許容最大入力は外径把握時の2/3となる。  
許容最大入力以外の項目は外形把握の場合と同じ。

ABOVE  
SPECS

AT MAX PERMISSIBLE INPUT FORCE  
(MAX. STATIC GRIPPING FORCE AND  
MAX. PERMISSIBLE SPEED ARE  
(ACTUAL VALUE) AT THE HEIGHT  
OF THE TOP OF SERRATION TO 19mm)

THE MAX PERMISSIBLE INPUT FORCE OF  
INSIDE GRIP IS 2/3 OF THE MAX  
PERMISSIBLE INPUT FORCE OF OUTSIDE GRIP.  
ITEMS OTHER THAN MAX PERMISSIBLE INPUT FORCE  
ARE THE SAME AS OUTSIDE GRIP.

CAREER				SCALE	TYPE	DL208	WEIGHT	kg
MANAGER	CHIEF	DRAWN BY		2:3	NAME	パワーチェック 8 POWER CHUCK 8		
KITAGAWA IRON WORKS CO.,LTD.			DATE	3RD ANGLE	DL208 ガイケイ DL208 OUTSIDE VIEW			
				DRW NO.	61P 26 1683			