

近接スイッチ
(付属しません)
Proximity switch
(It is not included.)

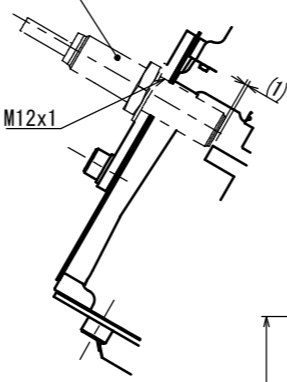

近接スイッチ
(付属しません)
Proximity switch
(It is not included.)

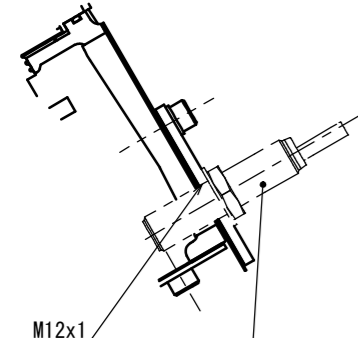

プラグ
Plugs

2x2xRc1/2

KITAGAWA

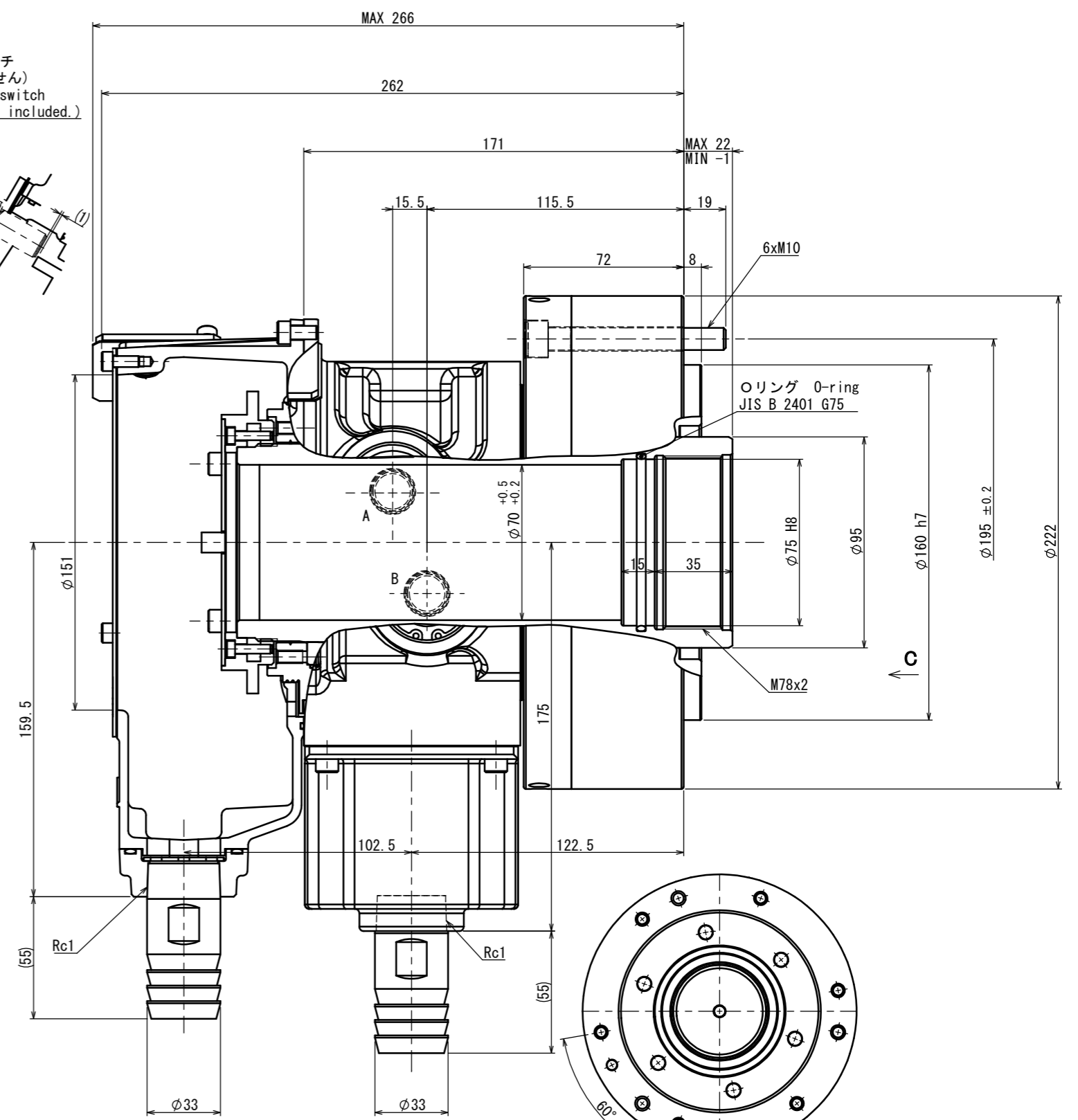

リング O-ring
JIS B 2401 G75

6xM10

φ75 H8

φ95

φ160 h7

φ195 ±0.2

φ222

M78x2

15

35

175

122.5

102.5

159.5

φ151

Rc1

φ33

φ33

φ70 +0.2

φ70 +0.2

MAX 22

MIN -1

171

262

MAX 266

19

8

72

115.5

15.5

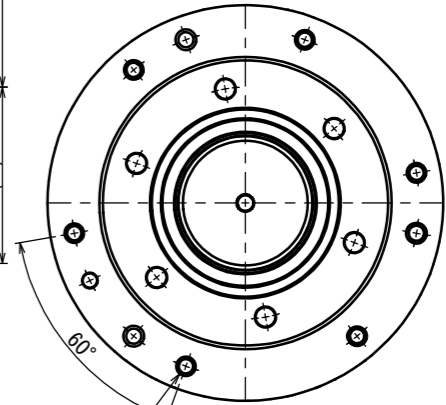

6xM10取付ボルト(等配)
Tighten bolts
(Equi-spaced)

SPECIFICATIONS	
PISTON DIA	165 mm
PISTON STROKE	23 mm
PISTON THRUST (OIL PRESSURE AT 3.3 MPa)	PUSH 45.3 kN
	PULL 43.0 kN
PISTON THRUST (OIL PRESSURE AT 4.0 MPa)	PUSH 56.4 kN
	PULL 53.6 kN
MAX.OPERATION PRESSURE	4.0 MPa
MAX.SPEED	4500 min ⁻¹
MASS	27.5 kg
MOMENT OF INERTIA	0.086 kg · m ²
OIL LEAKAGE ISO VG 32 50°C 3.0MPa	4.3 L/min

For B-210
B-210用

Belong 付属品

- 1. 六角穴付ボルト M10x80 :6ヶ
Hex. socket head cap screw M10x80 :6 pcs.
- 2. ホースニップル φ33 :2ヶ
Hose nipple φ33 :2 pcs.

C (1:3)

CAREER		SCALE	3:5	TYPE	SR1670C
APPROVAL	INSPECTION	DRW	3D	NAME	ROTARY HYDRAULIC CYLINDER
Kitagawa Corporation			DATE	DRW NO.	SR1670C OUTSIDE VIEW
					61R298093 0 1/1 P