



CHUCK

中実ロングストロークパワーチャック (ショートテーパー) Closed Centre Power Chuck (Long Stroke, Direct Mount) NL-A series

スピンドルノーズ対応バックプレート付き
Chuck Adaptor is equipped to suit Spindle Nose
突起物ワークも確実に把握
Flange work-pieces securely gripped

*CE対応品 *CE correspondence



スタンダードチャック
Standard Chuck

■ 寸法図 Dimensional Drawings

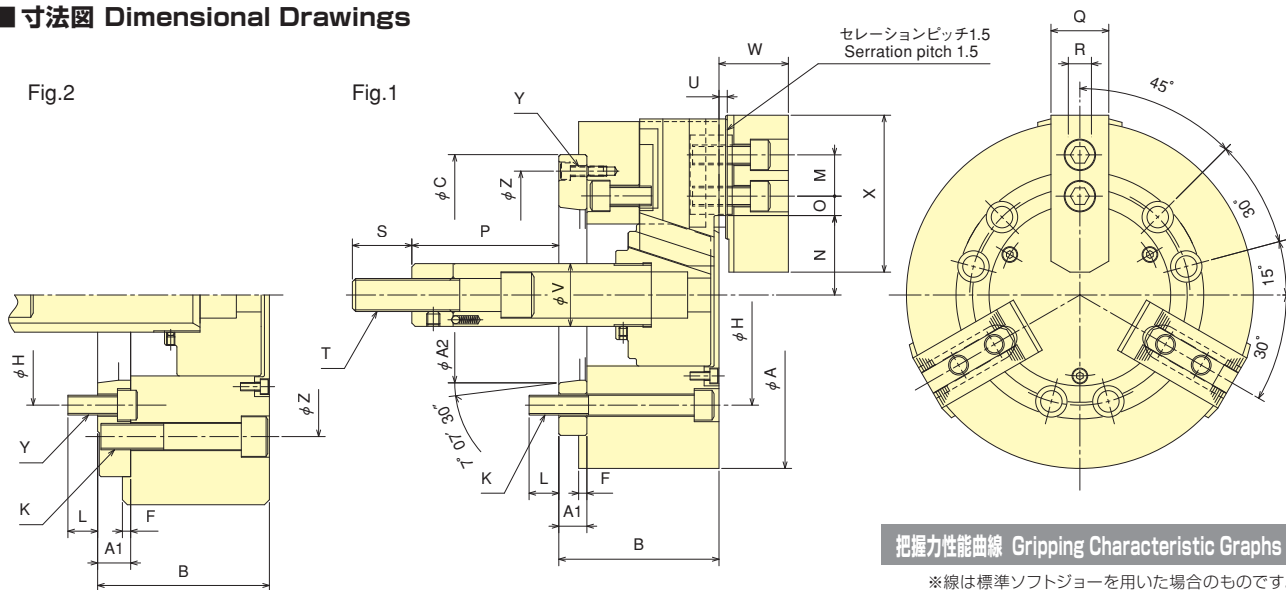

把握力性能曲線 Gripping Characteristic Graphs

*線は標準ソフトジョーを用いた場合のものです。
*With standard blank soft top jaw.

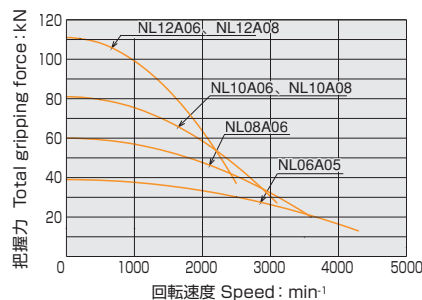

■ 寸法表 Dimensions ※NL10A06, NL12A06はFig.2による。*NL10A06 and NL12A06 are based on Fig. 2.

寸法 型式 Model	A	B	C	F	H	K	L	M	N max.	N min.	O max.	O min.	P max.	P min.	Q	R	S	T	U	V	W	X	Y	Z	A1	A2
NL06A05	165	84	140	5	1048	6-M10	14	20	40.5	34	13.75	9.25	86.5	66.5	31	12	36	M16	4	34	35	72	3-M6	116	15	82.563
NL08A06	210	97	170	5	1334	6-M12	18	25	48.1	40	20.75	11.75	114	89	35	14	36	M20	5	38	42	95	3-M6	150	17	106.375
NL10A06	254	104	220	5	1334	6-M16	18	30	54.4	45.35	29.5	11.5	141	113	40	16	36	M20	5	45	46	110	6-M12	171.4	20	106.375
NL10A08	254	102	220	5	171.4	6-M16	25	30	54.4	45.35	29.5	11.5	143	115	40	16	36	M20	5	45	46	110	3-M8	190	18	139.719
NL12A06	304	120	220	6	1334	6-M16	18	30	65.7	56	42.75	12.75	3	-27	50	18	46	M24	5	50	54	129	6-M12	171.4	20	106.375
NL12A08	304	118	220	6	171.4	6-M16	25	30	65.7	56	42.75	12.75	1	-29	50	18	46	M24	5	50	54	129	3-M8	190	18	139.719

■ 仕様表 Specifications ※把握径/把握範囲は標準のソフトジョーを使用した場合。*Gripping dia./gripping range is with standard soft jaws.

仕様 型式 Model	把握径 Gripping range mm	ジョーストローク Jaw Stroke (diameter) mm	プランジャストローク Plunger Stroke mm	許容最大入力 Max. Draw Bar Pull Force kN	最大静的把握力 Max. Gripping Force kN	許容最高回転速度 Max. Speed min ⁻¹	質量 (標準ソフトジョー付) Net Weight with Soft top jaws kg	慣性モーメント Moment of Inertia kg·m ²	適合シリンダ Matching Cylinder	許容最大油圧 Max. pressure MPa	標準ソフトジョー Matching Soft top jaw	適合ハードジョー Matching Hard top jaw	主軸呼び径 Spindle nose size	
NL06A05	165	21	13	20	21	39	4300	12.5	0.048	Y1020R/RE47	3.0	SJ06B1	HB06B1	A2-5
NL08A06	210	21	16.2	25	30	60	3600	24.5	0.148	Y1225R/RE47	2.9	SJ08B1	HB08A1	A2-6
NL10A06	254	24	18.1	28	40	81	3100	40	0.335	Y1530R/RE47	2.8	SJ10A1	HB10A1	A2-6
NL10A08	254	24	18.1	28	40	81	3100	37.6	0.326	Y1530R/RE47	2.8	SJ10A1	HB10A1	A2-8
NL12A06	304	29	19.4	30	54	111	2500	64.6	0.759	Y1530R/RE47	3.6	SJ12A1	HB12B1	A2-6
NL12A08	304	29	19.4	30	54	111	2500	63	0.750	Y1530R/RE47	3.6	SJ12A1	HB12B1	A2-8