



ROTARY CYLINDER

中空回転油圧シリンダ (ロングストローク) Large Thru-Hole High Speed Hydraulic Cylinder with Open Centre (Long Stroke) S-L series

中空のKITAGAWAスタンダードタイプ KITAGAWA standard thru-hole type

- ロングストロークタイプ
Long piston stroke
 - ロックバルブ、リリーフバルブ内蔵
Built-in check valve and relief valve
- *CE対応品 (確認装置付のみ)
*CE correspondence (Only series with checking device)



■ 寸法図 Dimensional Drawings

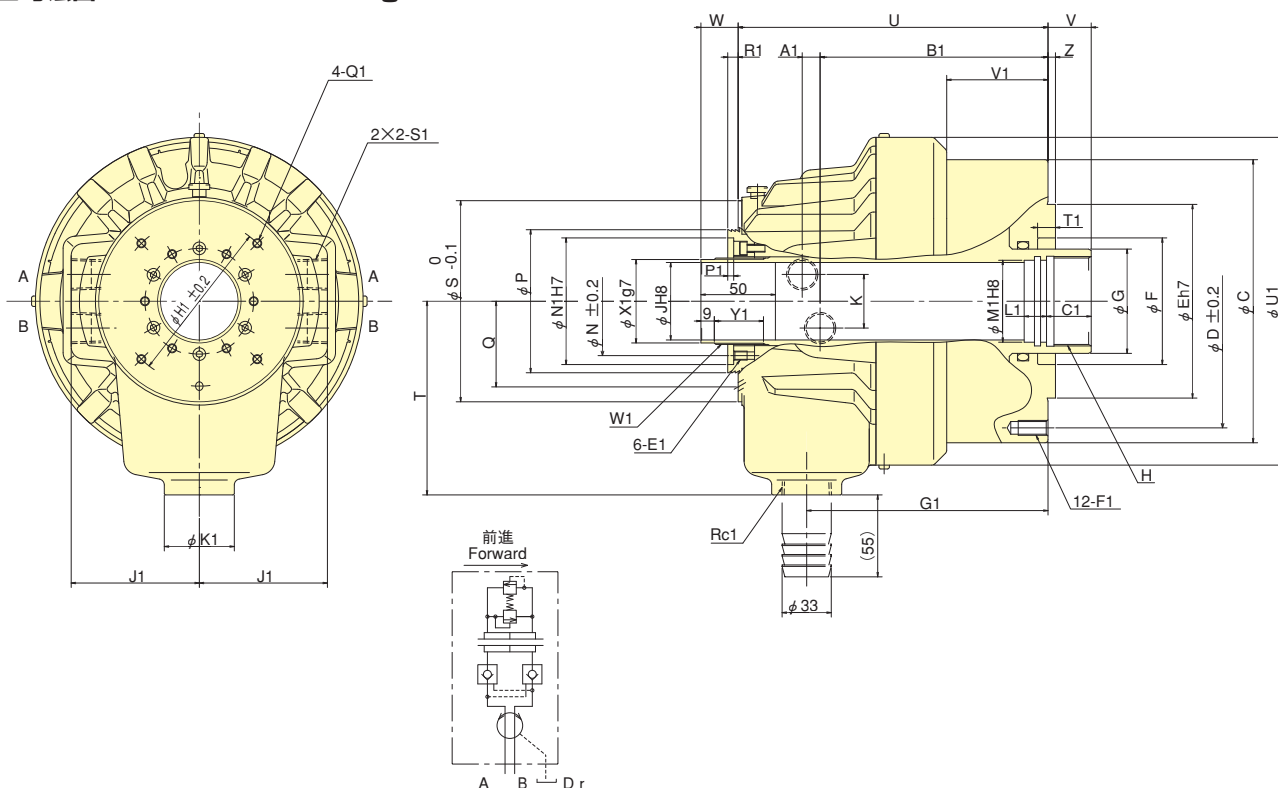

■ 寸法表 Dimensions

寸法 Dimensions Model	C	D	E	F	G	H	J 貫通穴径 Thru-hole	K	N	P	Q	S	T	U	V max.	V min.	W max.	W min.	Z	A1	B1
S1246L	155	130	100	80	65	M55×2.0	46	36	64	85	51.5	116	115	200	27	-5	57	25	5	11.5	147.5
S1552L	190	170	130	85	70	M60×2.0	52	36	73	96	57.5	135	130	208	29	-5	59	25	5	12	153
S1875L	215	190	160	120	95	M85×2.0	75	36	98	121	70.5	164	160	241	35	-5	65	25	5	17.5	169.5
S2091L	240	215	180	140	110	M100×2.0	91	34	108	138	79	180	185	268	45	-5	75	25	5	21	188

寸法 Dimensions Model	C1	E1 深さ depth	F1 深さ depth	G1	H1	J1	K1	L1	M1	N1	P1	Q1 深さ depth	R1	S1	T1	U1	V1	W1	X1	Y1
S1246L	30	M6×9	M10×20	156	98	76	47	15	50	76	4	M5×10	6	Rc1/2	12	200	67	M52×1.5	50	33
S1552L	30	M6×9	M10×20	162	110	86	47	15	55	85	4	M6×12	7	Rc1/2	12	220	68	M58×1.5	56	33
S1875L	35	M6×9	M10×20	182.5	155	101	47	15	80	108	4	M6×12	7	Rc1/2	12	242	74	M84×2.0	81	33
S2091L	35	M6×14	M12×24	203	165	110	47	15	95	120	4	M6×12	7	Rc1/2	12	267	86	M99×2.0	96	38

■ 仕様表 Specifications

仕様 Specifications Model	内径 Piston Dia. mm	ピストンストローク Piston stroke mm	ピストン表面積 Piston Area cm ²	ピストン推力 Draw bar kN(kgf)	最高使用油圧力 Max. Operation Pressure MPa(kgf/cm ²)	許容最高回転速度 Max. Speed min ⁻¹	慣性モーメント Moment of inertia kg·m ²	質量 Net Weight kg	ドレン量 Leakage ℓ/min	
S1246L	125	32	100	89 (3875)	33.0 (3365)	4.0 (40.8)	7000	0.022	12.8	3.0
S1552L	155	34	161	150 (6118)	56.0 (5710)	4.0 (40.8)	6200	0.058	17.0	3.9
S1875L	180	40	198	183 (7546)	69.0 (7036)	4.0 (40.8)	4700	0.100	26.8	4.2
S2091L	205	50	252	234 (9585)	88.0 (8973)	4.0 (40.8)	3800	0.160	34.1	4.5

シリンダ
Cylinder